



STM Truck Mounted Forklift Series

STM55 (5,500 lb)

STM55P (Pantograph)

STM55LP (Low Profile)

STM70 (7,000 lb)

- **Powerful**
- **Dependable**
- **Versatile**

 **SELICK**

STM Series rough terrain forklifts

5 500 or 7 000 lbs capacity @ 24" load centre

ENGINE

- Kubota V2203M naturally aspirated, low noise, low emission, water cooled, diesel engine
- Water separator
- Precleaner
- Single-element air filter
- Cold weather starting aid (glow plug)
- Fuel capacity: 9 gallons (34 L)

TRANSMISSION

- Hydrostatic transmission
- Full-time 3-wheel drive
- Inching control for precise load placement
- Anti-stall
- Traction control (improves performance on rough terrain)

OPERATOR COMPARTMENT

- Side-mount operator station provides increased visibility over loads of all sizes
- Operator's compartment meets or exceeds ANSI B56.6 FOPS/ROPS standard
- Adjustable seat with retractable seatbelt
- Automotive-style controls
- Latched operator's manual compartment

ELECTRICAL

- Sealed fuse box
- Two front and one rear adjustable halogen work lights
- Safety lighting includes work lights and LED brake lights

STEERING

- Priority power-assist steering

INSTRUMENTS

- All-in-one dashboard instrument cluster includes hour meter/fuel gauge. Indicator lights include: Hydraulic oil temperature, air filter restriction, battery, engine temperature, cold start and trac-lock
- Horn
- Backup alarm
- Neutral safety start

HYDRAULICS

- 5-spool hydraulic valve with easy-to-reach controls
- Stabilizers
- Mounting pressure release circuit

MAST ASSEMBLIES

- Corrosion resistant chain
- Standard lift heights of 8 ft, 10 ft and 12 ft

CARRIAGES

- 48" ITA Class III B hook
- 20° rotator (poultry)

OPTIONAL EQUIPMENT

- Tilt steering column
- Beacon light - strobe
- Tire packages
- Cold weather package
- Block heater
- Poultry package
- Custom paint

MOUNTS

- Universal easy-to-install mounts fit most tandem axle truck/trailers

STM Series rough terrain forklifts

5 500 or 7 000 lbs capacity @ 24" load centre

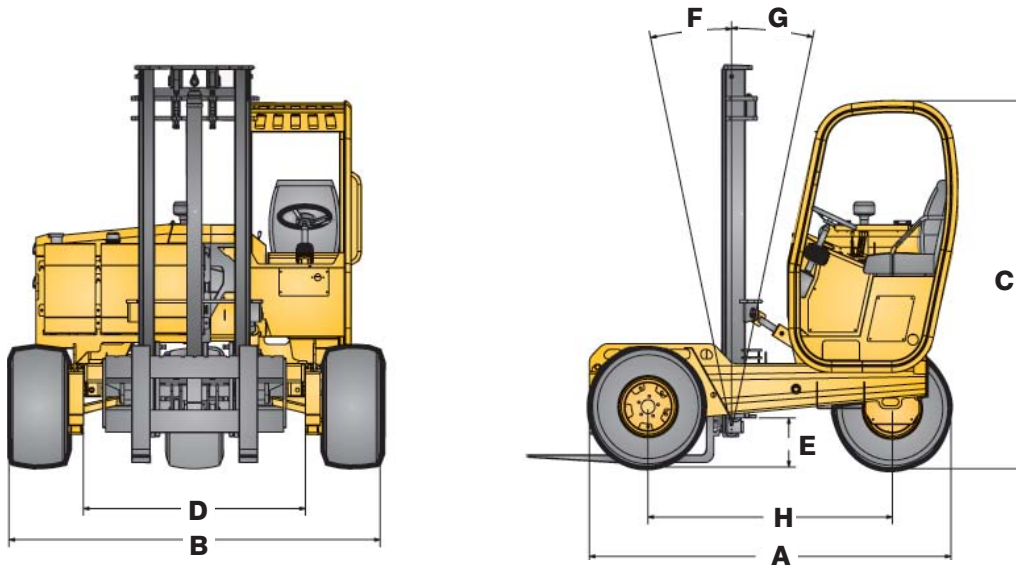

MODEL	REF	STM55	STM55P	STM55LP	STM70
Lift capacity @24" load centre		5 500 lbs/2 500 kg	5 500 lbs/2 500 kg	5 500 lbs/2 500 kg	7 000 lbs/3 175 kg
Base operating weight		6 200 lbs/2 812 kg	7 400 lbs/3 357 kg	7 600 lbs/3 447 kg	6 800 lbs/3 084 kg
Overall length (without forks)	A	102"/2 591 mm	105.5"/2 680 mm	111"/2 819 mm	105.5"/2 680 mm
Overhang		64"/1 626 mm	72"/1 829 mm	72"/1 829 mm	68"/1 727 mm
Overall width	B	100"/2 540 mm	100"/2 540 mm	96"/2 438 mm	100"/2 540 mm
Height to top of overhead guard	C	96"/2 438 mm	96"/2 438 mm	82"/2 083 mm	96"/2 438 mm
Frame opening	D	60"			
Outside turning radius		120"/3 048 mm	123"/3 124 mm	123"/3 124 mm	123"/3 124 mm
Mast sideshift		6"/152 mm	6"/152 mm	5"/127 mm	6"/152 mm
Mast underclearance	E	12"/305 mm			
Mast tilt - forward	F	12°			
Mast tilt - rearward	G	10°	10°	8°	10°
Gradeability		25%			
Wheelbase	H	66"/1 676 mm	74"/1 880 mm	76"/1 930 mm	74"/1 880 mm
Tire size		31 - 15.5 - 15	31 - 15.5 - 15	29 - 12.5 - 15	31 - 15.5 - 15
Engine manufacturer/model		Kubota V2203M			
Engine type		Diesel, water cooled (naturally-aspirated)			
Cylinders		4			
Engine output (horsepower)		50 hp			
Transmission type		Hydrostatic			



— All Sellick forklifts meet or exceed all ANSI B56.6 safety standards. —
 -www.sellickequipment.com-

Sellick Equipment Limited • P.O. Box 1000/358 Erie Street North • Harrow, Ontario, Canada • N0R 1G0 • 519-738-2255



Power & Performance

The STM Series of truck mounted forklifts offer the following benefits:

- Hydrostatic transmission with inching control for precise load placement
- Simple and safe mounting on the back of most truck/trailer with Sellick mounting kits.
- Offset operator seat allows for full visibility
- Four models (STM55/STM55P/STM55LP/STM70) to handle the needs of any industry or application
- Ergonomic operators compartment with fingertip control reduces fatigue and increases productivity.
- Full time 3WD with traction control and anti-stall

Working for you

Built in the Sellick tradition of quality & reliability, the STM series is supported by a network of long-established material handling dealers that provide prompt parts and service. All Sellick products are backed by one of the best warranties in the business.

setting the standard

Sold & serviced by:



Sellick Equipment Limited
 P.O. Box 1000/358 Erie Street North
 Harrow, Ontario, Canada N0R 1G0
 519-738-2255 • sellick@mnsi.net

All Sellick forklifts meet or exceed all ANSI B56.6 safety standards.